

Ventec Life Systems®

# HomeFill® Oxygen System

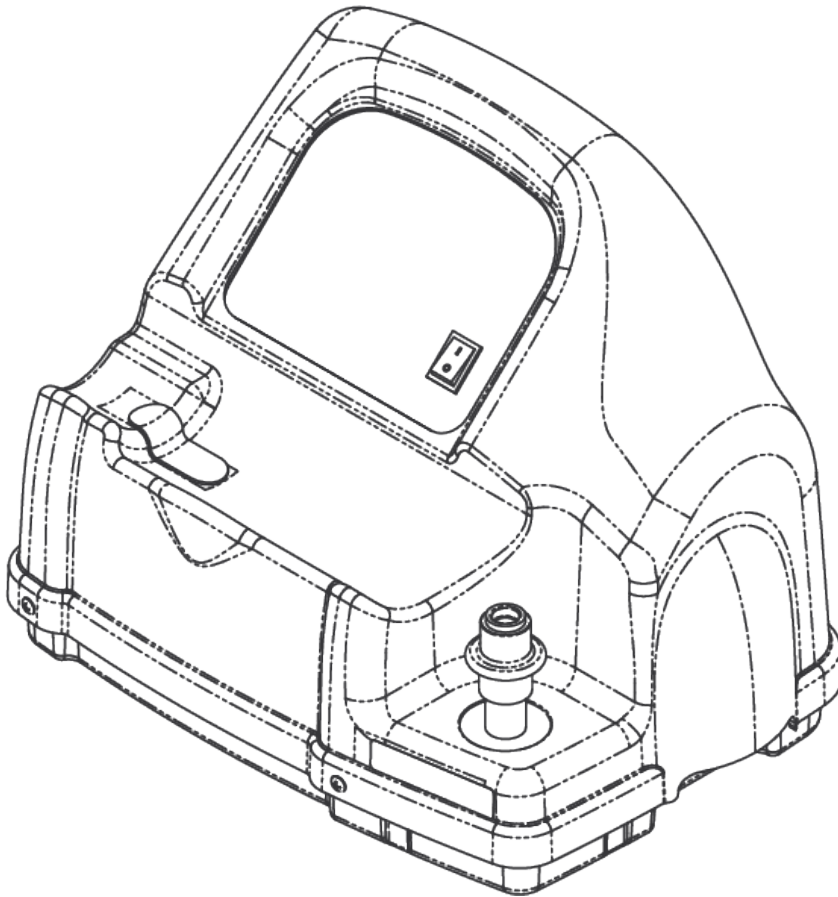

IOH200

en  
Compressor  
User Manual



This manual **MUST** be given to the user of the product **BEFORE** using this product, read this manual and save for future reference.

INSIDE FRONT COVER  
INTENTIONALLY LEFT BLANK

# Contents

---

1. Introduction .....	5
2. General .....	6
2.1 Quick Start Guide .....	6
2.1.1 Quick Start Label .....	6
2.2 Symbols .....	7
2.2.1 Symbols in the Manual .....	7
2.2.2 Symbols on the Product .....	8
2.3 Intended Use .....	9
2.4 Indications For Use .....	10
2.5 Contraindications .....	10
2.6 Optional Accessories .....	10
2.6.1 Ready Rack .....	10
2.7 Replacement Parts .....	11
3. Safety .....	12
3.1 General Guidelines .....	12
3.2 Provider Information .....	15
3.3 Double-Insulated Products .....	15
3.4 EMC Information .....	15
4. Components .....	17
4.1 Label Locations .....	17
4.2 Symbols on the Labels .....	17
4.2.1 Control Panel Label .....	17
5. Setup .....	19
5.1 Unpacking .....	19
5.2 Compressor Initial Setup Checklist .....	19
5.3 Choosing a Location .....	20
5.3.1 Ready Rack .....	20
5.4 Transporting the Compressor .....	21
5.5 Installing the Power Cord .....	22
5.6 Connecting the Compressor to the Concentrator .....	22
5.6.1 Connecting the Compressor to an approved Ventec® Concentrator .....	22

6. Usage .....	23
6.1 Compressor Operation Checklist .....	23
6.2 Cylinder Prefill Inspection .....	23
6.2.1 Hydrostatic Testing Date .....	24
6.2.2 External Examination .....	24
6.3 Connecting the Cylinder to the Compressor .....	25
6.4 Disconnecting the Cylinder from the Compressor .....	26
6.5 Turning the Compressor On and Off .....	27
7. Maintenance .....	29
7.1 Maintenance Information .....	29
7.2 Wear and Tear .....	30
7.3 Service Life .....	30
7.4 Cleaning the Compressor Filter .....	30
7.5 Cleaning the Cabinet .....	31
7.6 Replacing the Fuse .....	31
8. After Use .....	31
8.1 Disposal .....	31
9. Troubleshooting .....	32
9.1 Troubleshooting Label .....	32
9.2 Troubleshooting .....	33
10. Technical Data .....	34
10.1 Technical Description .....	34
10.2 Specifications .....	34
10.3 Electromagnetic Compliance (EMC) .....	36
11. Warranty .....	39
11.1 Limited Warranty .....	39

# 1. Introduction

---

On February 1, 2023, Ventec® Life Systems, dba React Health, completed the purchase of the Invacare Respiratory product line. Invacare branded products sold before this date are compatible with Ventec or React branded product sold after this date. Any references to “approved” concentrators, cylinders or accessories noted in this manual are inclusive of Invacare, Ventec and React branded products.

## 2. General

### 2.1 Quick Start Guide

#### 2.1.1 Quick Start Label



#### IMPORTANT!

The Quick Start Label is for reference ONLY. It is imperative to read the manual in its ENTIRETY for full instructions.

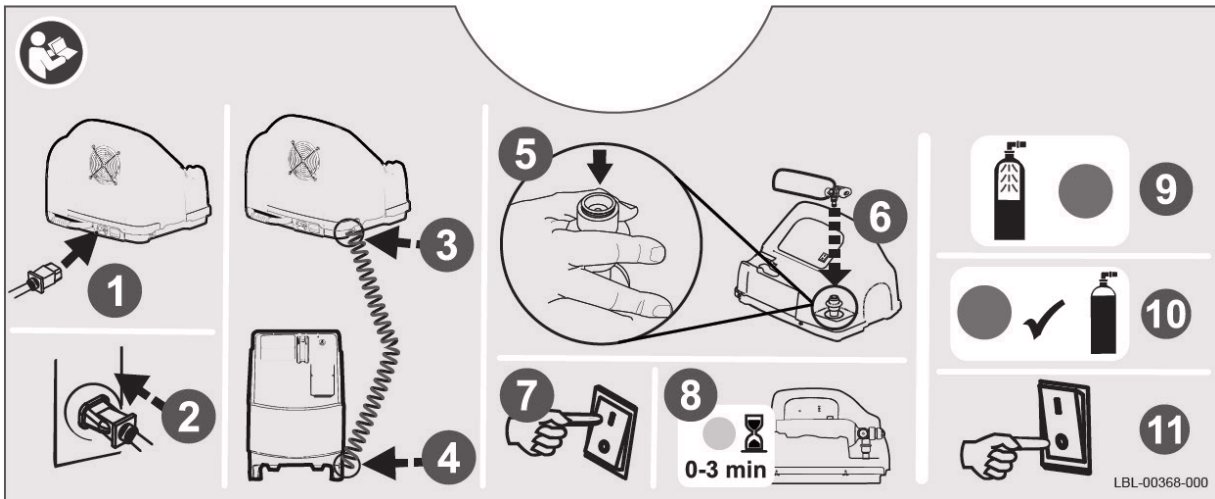

Turn the concentrator on

1. Connect the power cord to the compressor.
2. Plug in the power cord.
3. Connect the fill tubing to the compressor.
4. Connect the fill tubing to the concentrator.
5. Push down and hold the coupler sleeve.
6. Connect the cylinder to the coupler.
7. Turn the compressor ON.
8. Wait 0-3 minutes for the compressor to start up. The yellow light will come on.
9. Wait as the cylinder fills. The green (filling) light will come on.
10. Note when the cylinder is full. A green (full) light will come on.
11. Turn the compressor OFF.

## 2.2 Symbols

### 2.2.1 Symbols in the Manual

Signal words are used in this manual and apply to hazards or unsafe practices which could result in personal injury or property damage.

See the information below for definitions of the signal words.



#### **DANGER!**

Danger indicates an imminently hazardous situation which, if not avoided, will result in death or serious injury.



#### **WARNING!**

Warning indicates a potentially hazardous situation which, if not avoided, could result in death or serious injury.



#### **CAUTION!**

Caution indicates a potentially hazardous situation which, if not avoided, may result in property damage or minor injury or both.



Indicates a hazardous situation that could result in damage to property if it is not avoided

















Gives useful tips, recommendations and information for efficient, trouble-free use.







This symbol identifies a list of tools, components and items you will need to perform certain tasks.

## 2.2.2 Symbols on the Product

Symbols used on the compressor, compressor packaging or the oxygen cylinder are listed in the following table. For information about other symbols, see 4.2.1 *Control Panel Label*, page 17.

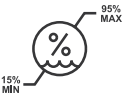
SYMBOL	DESCRIPTION
	Read the manual (compressor) i The color of the symbol background is blue on product labels.
	Read the manual (cylinder)
	Electrical Hazard
	Alternating Current
	Type BF equipment — Applied Parts
	Power Switch ON
	Power Switch OFF
	DO NOT Smoke i The color of the circle with the diagonal bar is red on product labels.
	No Open Flame i The color of the circle with the diagonal bar is red on product labels.
<b>IP21</b>	Protected against solid foreign objects of 12.5 mm diameter and greater. Protected against vertically falling water drops.
	Class II, Double Insulation. Refer to see 3.3 <i>Double-Insulated Products</i> , page 15
	Keep dry in transport or storage and during use.
	Fuse
	Oxidizer i The color of the symbol background is yellow on product labels.
	Non-flammable Gas, Class 2 Type Oxygen i The color of the symbol background is green on product labels.



SYMBOL	DESCRIPTION
	Transport and Storage Temperature
	Transport and Storage Humidity
	Recycle
	Recycle this product—see 8.1 Disposal, page 31
	Manufacturer

## 2.3 Intended Use

The Ventec HomeFill® compressor is designed to be used only with oxygen concentrators that meet the input specifications listed in see 10.2 Specifications, page 34.

DO NOT use the HomeFill® compressor with anything other than an oxygen concentrator that meets the compressor input requirements.

The intended use of a Ventec HomeFill compressor is an accessory device to an oxygen concentrator that enables the patient to refill custom portable oxygen cylinders for personal use.

This product is intended for single-patient use only in the indoor home care environment and is not to be used for bulk cylinder refilling.

No specific product knowledge or training, other than what is contained in this manual, is required to operate the product.

It is not intended for supplying oxygen therapy during refilling.

This product is intended to be used by or under adult supervision only after reading and understanding the instructions and warnings of this user manual.



### WARNING!

#### Risk of Injury or Damage

- The use of this device is limited to refilling a specific patient's own oxygen cylinders. The designated cylinders MUST be used ONLY by the specific oxygen patient and are not to be distributed to any other individual for any purpose.
- No other use of this device is indicated.

## 2.4 Indications For Use

Indicated to enable the patient to refill custom portable oxygen cylinders for personal use.

## 2.5 Contraindications

There are no known contraindications.

## 2.6 Optional Accessories



### WARNING!

#### Risk of Injury or Damage

- Use of non-Ventec accessories may result in serious injury or damage.
- Ventec products are specifically designed and manufactured for use in conjunction with Ventec accessories, such as Ready Racks, cylinders, and the replacement parts listed below..
- Accessories designed by other manufacturers have not been tested by Ventec and are not recommended for use with Ventec products.
- DO NOT use non-Ventec accessories. To obtain Ventec accessories, contact Ventec by phone or at [www.reacthealth.com](http://www.reacthealth.com).

### 2.6.1 Ready Rack

The compressor should sit on a hard, flat, stable surface, such as the Ready Rack.



The HomeFill Ready Rack is sold separately and is used to position the HomeFill compressor on top of an oxygen concentrator.

Approved Concentrator and Ready Rack Model Information	
Concentrator	Ready Rack Product ID
Perfecto2™, Perfecto2™ V	IOH270
Platinum® 5NXG	IOH280
Platinum® 10	IOH260

**WARNING!****Risk of Injury or Damage**

- DO NOT install this equipment without first reading and understanding this instruction sheet. If you are unable to understand the Warnings, Cautions and Instructions in this manual, contact your Home Healthcare Dealer before attempting to install this equipment. Otherwise, injury or damage may result. Separate the HomeFill compressor from the Ready Rack prior to transporting. Children should ALWAYS be supervised around the HomeFill unit. When used with the HomeFill Ready Rack or similar elevated support surfaces, a child could pull over any such stand and cause the unit to fall. Failure to observe this warning may result in personal injury or product damage.

**CAUTION!****Risk of Injury or Damage**

- The HomeFill Ready Rack is designed for use only with approved Ventec concentrators and Ventec HomeFill compressors. DO NOT attempt to use this Ready Rack with other products. Otherwise, damage to the Ready Rack and/or the other devices may occur.

**WARNING!****Risk of Injury or Damage**

- DO NOT move the concentrator while the HomeFill compressor is on the Ready Rack. Separate the HomeFill compressor from the Ready Rack prior to transporting.



For information about installing and using the Ready Rack, refer to the Ready Rack instructions or access the instructions on the React Health website.

## 2.7 Replacement Parts

The following replacement parts are available from Ventec:

- Supply Line, part number 1105177
- Power Cord, part number 1112949

## 3 Safety

---

### 3.1 General Guidelines

**DANGER!****Risk of Death, Injury or Damage**

Improper use of the product may cause death, injury or damage. This section contains important information for the safe operation and use of this product.

- DO NOT use this product or any available optional equipment without first completely reading and understanding these instructions and any additional instructional material such as user manuals, service manuals or instruction sheets supplied with this product or optional equipment.
- If you are unable to understand the warnings, cautions or instructions, contact a healthcare professional, dealer or technical personnel before attempting to use this equipment.
- Check ALL external components and carton for damage. In case of damage, or if the product is not working correctly, contact a technician or Ventec for repair.
- To ensure the safe installation, assembly and operation of the HomeFill compressor, these instructions MUST be followed.
- THE INFORMATION IN THIS DOCUMENT IS SUBJECT TO CHANGE WITHOUT NOTICE.

**DANGER!****Risk Of Death, Injury or Damage From Fire**

Textiles, oil or petroleum substances, grease, greasy substances and other combustibles are easily ignited and burn with great intensity in oxygen-enriched air and when in contact with oxygen under pressure. To avoid fire, death, injury or damage:

- DO NOT SMOKE while using this device.
- DO NOT use near OPEN FLAME or IGNITION SOURCES.
- DO NOT use any lubricants on the compressor unless recommended by Ventec.
- NO SMOKING signs should be prominently displayed.
- Avoid creation of any spark near oxygen equipment. This includes sparks from static electricity created by any type of friction.
- Keep all matches, lighted cigarettes or other sources of ignition out of the room in which this compressor is located and away from where oxygen is being delivered.
- Keep the oxygen tubing, cord, and compressor out from under such items as blankets, bed coverings, chair cushions, and clothing and away from heated or hot surfaces, including space heaters, stoves, and similar electrical appliances.



**DANGER!**  
**Risk Of Death, Injury or Damage From Fire**

Textiles, oil or petroleum substances, grease, greasy substances and other combustibles are easily ignited and burn with great intensity in oxygen-enriched air and when in contact with oxygen under pressure. To avoid fire, death, injury or damage:

- DO NOT allow oil from your hands or other sources to come into contact with the compressor coupling or cylinder fittings.
- These substances may become flammable in the presence of oxygen and cause injury. Avoid touching the cylinder fitting whenever possible. Example of items to avoid are hand creams or lotions, cooking oils, suntan oils or sunblocks and similar oily products. If you use these types of products Ventec suggests you wash your hands prior to using the HomeFill unit. If the cylinder fitting should come in contact with such substances it should be cleaned off with a damp cloth prior to connecting it to the compressor.
- NEVER oil or lubricate the compressor coupler or cylinder fittings. NEVER use any penetrating oil or lubricant such as WD-40® or 3-in-1 Oil®. If connection difficulty is experienced verify that the cylinder fitting is being inserted straight down into the compressor coupler. If continued difficulty is experienced contact your supplier for assistance.



**DANGER!**  
**Risk of Electric Shock**

This unit contains moving and high-pressure components. There are no user-serviceable parts inside the cover. To avoid electric shock, injury or death:

- DO NOT remove the cover.
- Refer servicing to qualified personnel.



**WARNING!**  
**Risk of Injury or Damage**

Blocking the air flow into and out of the compressor may cause injury or damage.

- NEVER block the air openings of the product or place it on a soft surface, such as a bed or couch, where the air opening may be blocked.
- Keep the openings free from lint, hair and similar foreign items.



**WARNING!**  
**Risk of Injury or Damage**

A damaged product may malfunction and cause injury or damage. To avoid injury or damage:

- DO NOT get the compressor wet.
- If the compressor has a damaged cord or plug, if it is not working properly or if it has been dropped or damaged or submersed in water, call a qualified technician for examination and repair.



**WARNING!**

**Risk of Injury or Damage**

- DO NOT use the compressor outdoors. Indoor use only.
- If any leakage of the oxygen cylinder is detected, DO NOT attempt to use the cylinder. Turn the flow selector knob on the regulator to "Off". If leakage persists, place the cylinder outdoors and notify your Home Health Care Provider or Service Representative of this condition.
- Children should ALWAYS be supervised around the HomeFill unit. When used with the HomeFill table or similar elevated support surfaces, a child could cause the unit to fall. Failure to observe this warning may result in personal injury or product damage.



**WARNING!**

**Risk of Injury or Damage**

The HomeFill is equipped with a high-pressure relief valve to ensure the user's safety. When activated, this safety feature will make an extremely loud noise. If this noise occurs, to avoid injury or damage:

- Turn the unit Off, and contact your Home Health Care Provider or Service Representative.



**WARNING!**

**Risk of Injury or Damage**

If improperly positioned and secured, the power cord and interconnect hose can cause injury due to tripping, falling and strangulation. Product damage may also occur.

- Properly store and position electrical cords and/or tubing to prevent tripping and strangulation hazards.
- Avoid positioning power cords across areas of high traffic.
- Before moving or repositioning either the compressor or the concentrator, ALWAYS disconnect the AC power cords and the interconnect hose between the compressor and concentrator.



**CAUTION!**

Federal (statutory) law restricts this device sale to or on the order of a medical practitioner licensed by a governmental agency where he/she practices.

- ONLY a licensed medical practitioner may order the purchase or use of this device.

### 3.2 Provider Information

Before leaving a HomeFill compressor with a user, the following checklist **MUST** be completed:

- Make sure the pressure tests on the cylinder are current.
- Instruct the user on the safe operation of the concentrator, and review all warnings.
- Instruct the user on the safe operation of the HomeFill compressor, and review all warnings.
- Leave a copy of all warnings and filling instructions with the user.

### 3.3 Double-Insulated Products



#### **CAUTION!**

- **DO NOT** unplug the power cord by pulling on the cord. To unplug, grasp the plug not the cord; otherwise, damage may occur.

In a double-insulated product, two systems of insulation are provided instead of grounding. No grounding means is required on a double-insulated product, nor is a means for grounding to be added to the product. A double-insulated product is marked with the words "DOUBLE INSULATION" or "DOUBLE INSULATED" or the following symbol:

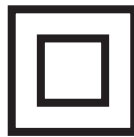

### 3.4 EMC Information



#### **WARNING!**

##### **Risk of Injury or Damage**

To reduce the risk of injury or product damage from interference with wireless equipment:

- Keep the compressor at least 9.8 ft (3.0 m) away from wireless communication equipment such as wireless home network devices, mobile phones, cordless phones and base stations, and walkie-talkies.



#### **WARNING!**

##### **Risk of Injury or Damage**

Use of accessories and cables other than those specified or provided by Ventec could result in increased electromagnetic emissions or decreased electromagnetic immunity of this equipment. This could result in improper operation.

Medical Electrical Equipment needs to be installed and used according to the EMC information in this manual.

This equipment has been tested and found to comply with EMC limits specified by IEC/EN 60601-1-2 for Type BF equipment. These limits are determined to provide reasonable protection against electromagnetic interference in a typical home healthcare environment.

Use of this equipment in an environment with higher levels of interference could affect the accuracy of the oxygen concentration in the cylinder. This equipment is not intended for use in a professional healthcare environment.

Portable and mobile RF communications equipment can affect the operation of this equipment.

Other devices may experience interference from even the low levels of electromagnetic emissions permitted by the above standard. To determine if the emissions from the compressor are causing the interference, turn off the compressor. If the interference with the other device operation stops, then the compressor is causing the interference. In such rare cases, interference may be reduced or corrected by one of the following measures:

- Reposition, relocate or increase the separation between the devices.
- Connect either line powered device to a different electrical power circuit.

*For additional EMC information, refer to 10.3 Electromagnetic Compliance (EMC), page 36.*



# 4 Components

## 4.1 Label Locations

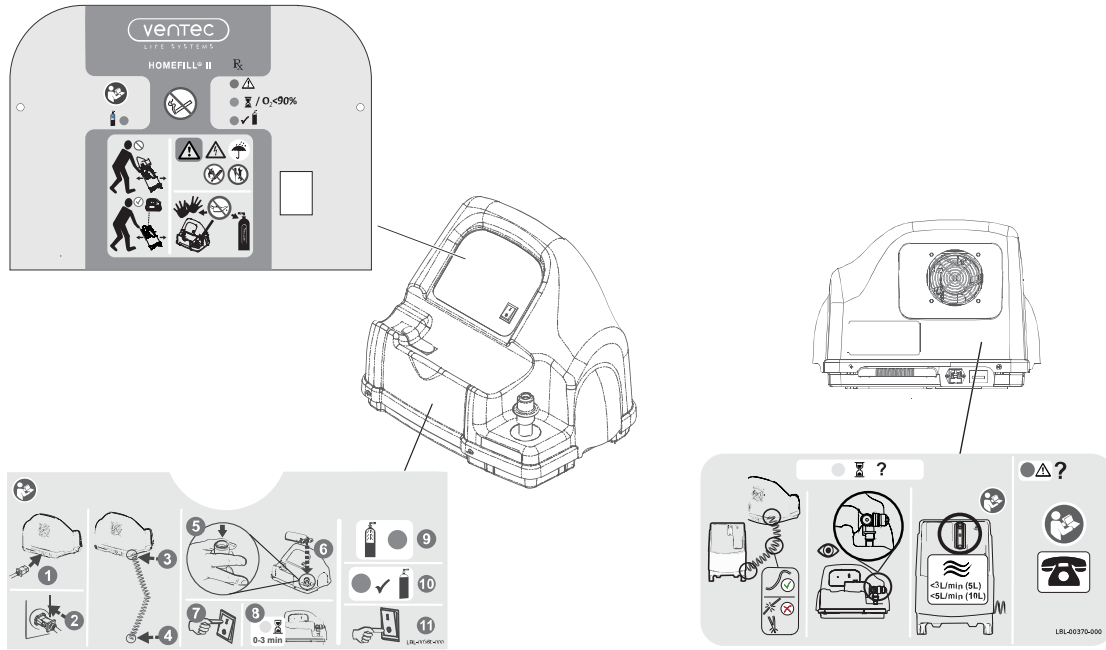

## 4.2 Symbols on the Labels



For information about the symbols on the Troubleshooting label, see 9.1 Troubleshooting Label, page 32.

### 4.2.1 Control Panel Label

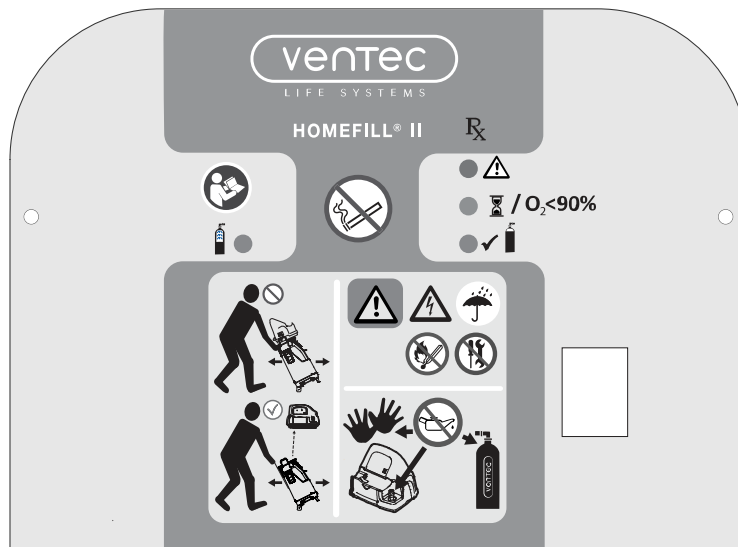

DO NOT use oil, grease, or any other lubricants, including hand lotion.



The color of the circle with the diagonal bar is red on product labels.



No Open Flame



The color of the circle with the diagonal bar is red on product labels.



**Not to be serviced by users**

 The color of the circle with the diagonal bar is red on product labels.



**Read the Manual**

 The color of the symbol background is blue on product labels.



**DO NOT Smoke**

 The color of the circle with the diagonal bar is red on product labels.



**Attention**



**Filling**

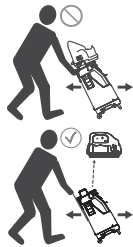

**DO NOT** move the concentrator while the HomeFill II compressor is on the Ready Rack. Separate the HomeFill compressor from the Ready Rack prior to transporting.

See see 5.4 *Transporting the Compressor*, page 21 and see 2.6.1 *Ready Rack*, page 10



**Keep Dry**



**Electrical Hazard**



**For prescription use ONLY**

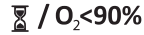

**Warming Up/Low Oxygen**



**Full**



*No oil, no grease, no lubricant (including lotion) on hands, on the compressor fillport and on the cylinder valve.*

## 5 Setup

### 5.1 Unpacking

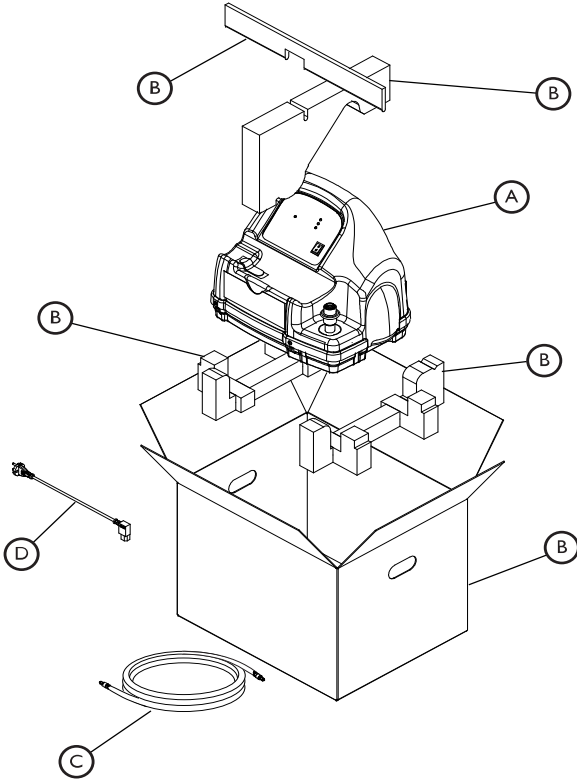
Diagram	labels	Diagram
	A	Compressor Assembly (part no. 1102311)
	B	Packaging Assembly (part no. 1102315)
	C	Supply Line Assembly (part no. 1105177)
	D	Power Cord (part no. 1112949)
	N/A	User Manual (not shown) (LBL-00371-000)

1. Check for any obvious damage to the carton or its contents. If damage is evident, notify the carrier or your local dealer.
2. Remove all loose packaging from the carton.
3. Carefully remove all of the components from the carton.

 Unless the compressor is to be used IMMEDIATELY, leave the compressor in its packaging for storage until use of the compressor is required.

### 5.2 Compressor Initial Setup Checklist

 **Providers ONLY** — Refer to see 3.2 Provider Information, page 15 before performing this procedure.

**Users ONLY** — Contact your Homecare provider or Ventec for assistance with the setup procedure and to report unexpected operation or events.

- Before operating the HomeFill compressor for the first time, complete the following checklist:
- Choose a location for the compressor.
- Transport the compressor to the desired location.
- Connect the power cord to the compressor.
- Connect the compressor to the concentrator.

## 5.3 Choosing a Location

For indoor use only. The compressor should be at least three inches away from walls, draperies or furniture to ensure sufficient air flow.

Avoid placing the compressor next to heaters, radiators or hot air registers.

DO NOT place in a closet.



### **WARNING!**

#### **Risk of Injury or Death**

Children should ALWAYS be supervised around the HomeFill unit. When used with the HomeFill Ready Rack or similar elevated support surfaces, a child could pull over any such stand, causing the unit to fall. Failure to observe this warning may result in personal injury or product damage.

### 5.3.1 Ready Rack

The compressor should sit on a hard, flat, stable surface, such as a table or the Ready Rack. For more information about the Ready Rack, see *2.6.1 Ready Rack, page 10*.

## 5.4 Transporting the Compressor



### WARNING!

NEVER transport a compressor with a cylinder connected to or stored on the compressor. Otherwise, injury or damage can occur.



### CAUTION!

When transporting the compressor, remove all connectors and be careful not to bump the compressor or the connectors into obstacles. Otherwise, damage to the compressor may occur.

To safely transport the compressor, use one of the following methods:

- One Hand - Grasp the hand grip (A) at the bottom rear of the compressor.
- Two Hands - Grasp the hand grips (B) on the sides of compressor.

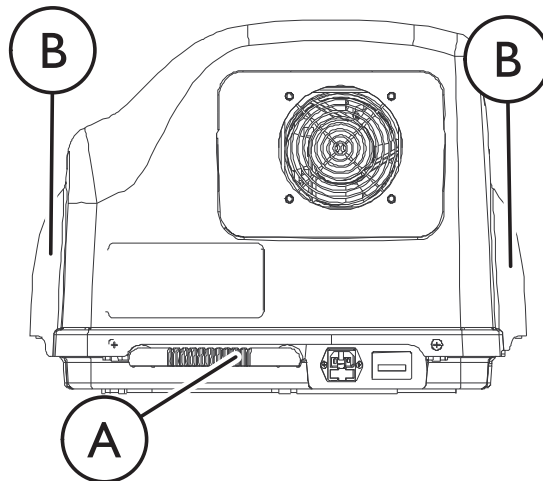



### WARNING!

#### Risk of Injury or Damage

- If you use a Ready Rack, DO NOT move the concentrator while the HomeFill compressor is on the Ready Rack. Separate the HomeFill compressor from the Ready Rack prior to transporting.

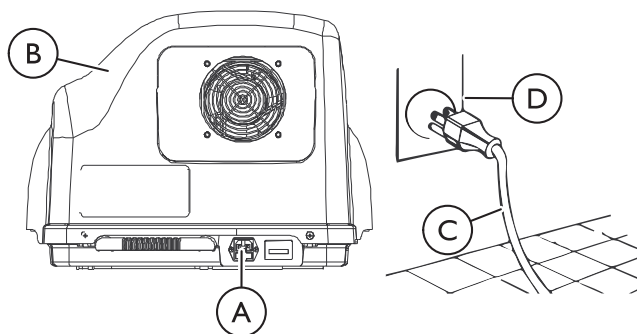
## 5.5 Installing the Power Cord



 This product will come with a polarized plug (one blade is wider than the other). As a safety feature, this plug will fit in a polarized outlet only one way. If the plug does not fit fully in the outlet, reverse the plug. If it still does not fit, contact a qualified electrician. **DO NOT** attempt to defeat this safety feature.

1. Choose a proper location. See 5.3 *Choosing a Location*, page 20.
2. Make sure the power switch is in the Off (O) position.
3. Plug the power cord into the electric connector (A) in the back of the compressor (B).
4. Plug the opposite end of the power cord (C) into the wall outlet (D).
5. Leave a minimum of 3 inches (7.6 cm) clearance to the power cord ends for disconnection access.

 The power inlet acts as the mains disconnection device to remove all power to the unit when the line cord is disconnected.

## 5.6 Connecting the Compressor to the Concentrator

### 5.6.1 Connecting the Compressor to an approved Concentrator

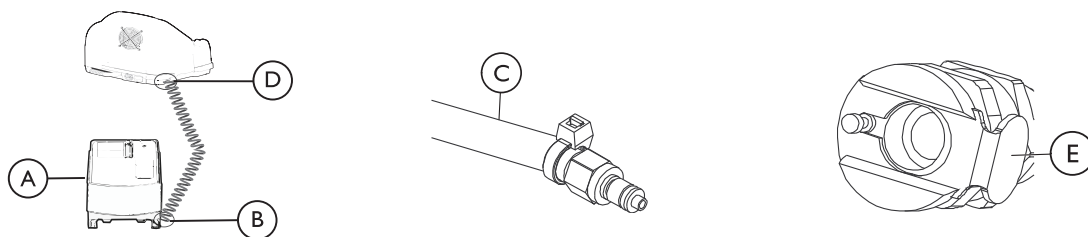

1. Insert one end of the interconnect hose (C) into the outlet fitting (B) on the back of the concentrator (A).
2. Insert the opposite end of the interconnect hose into the inlet fitting (D) on the side of the compressor.

 The metal tabs (E) on the concentrator outlet fitting (B) and the compressor inlet fitting (D) will pop out with an audible “click” when the end of the interconnect hose is properly installed.

## 6 Usage

### 6.1 Compressor Operation Checklist

Each time the HomeFill compressor is used to fill a cylinder, complete the following checklist:

- Ensure the concentrator has been On for at least 30 minutes. Refer to the concentrator user manual.
- Perform the prefill inspection on the cylinder.
- Connect the cylinder to the compressor.
- Push the compressor power switch to the On ( I ) position.
- Examine the indicator lights on the control panel.
- Disconnect and remove the full cylinder.
- Push the compressor power switch to the Off ( O ) position.
- To fill another cylinder, repeat this checklist.

### 6.2 Cylinder Prefill Inspection



#### WARNING!

- Use ONLY approved cylinders that have a HomeFill connection and a HomeFill label.
- All cylinders MUST be inspected before attempting to fill them. Otherwise, injury or damage may occur.

To identify a HomeFill-compatible cylinder (A), locate the following:

- HomeFill connector fill port (B)
- A black stripe (C) in the green area (D) on the top of the cylinder
- The HomeFill label (E)

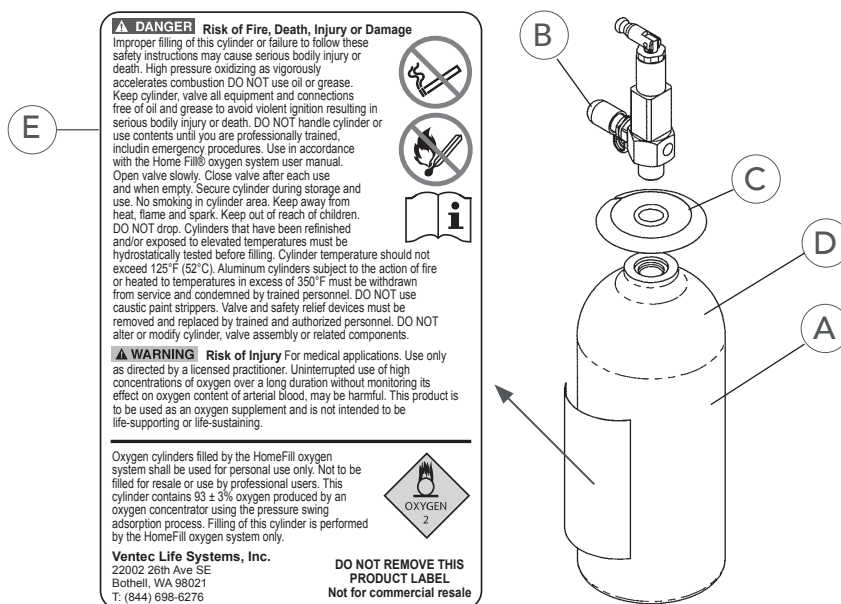

## 6.2.1 Hydrostatic Testing Date

Aluminum cylinders MUST undergo testing every five years.



### **WARNING!** **Risk of Injury**

- To reduce the risk of injury, DO NOT fill cylinders that have not been tested in the past five years. Otherwise, serious personal injury may result. Contact your dealer for replacement.

## 6.2.2 External Examination

1. Examine the outside of the cylinder for the following conditions, and replace the cylinder if they exist:
  - Dents or dings
  - Arc burns
  - Oil or grease
  - Any other signs of damage that might cause a cylinder to be unacceptable or unsafe for use
2. Examine the cylinder for evidence of fire or thermal damage. Evidence includes charring or blistering of the paint or other protective coating or heat-sensitive indicator. If fire or thermal damage is found, replace the cylinder.
3. Inspect the cylinder/regulator assembly, and replace it if the following conditions are found:
  - Debris, oil or grease
  - Noticeable signs of damage
  - Signs of corrosion inside the valve
  - Signs of excessive heat or fire damage



## 6.3 Connecting the Cylinder to the Compressor



### WARNING!

- DO NOT drop oxygen cylinders. Use two hands when handling or transporting oxygen cylinders. Otherwise, injury or damage may occur.
- DO NOT use a liquid leak detector to test for leaks.

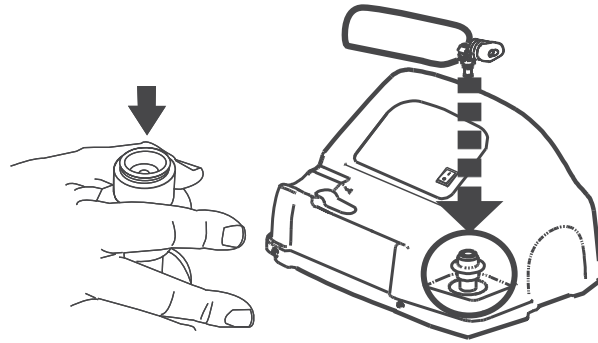

Fillport covers not shown for clarity.

1. Prior to each use, inspect the product for visible damage. See 6.2.2 *External Examination*, page 24. DO NOT use if any damage is found.  
If any label becomes illegible or lost, contact your dealer or provider.
2. Examine the cylinder gauge. If the cylinder pressure is less than 1500 psig, proceed to the next step.  
For the location of the cylinder gauge, refer to the cylinder manual.  
If the cylinder pressure is **greater** than 1500 psig, DO NOT attempt to top off the cylinder.  
It may not fill.
3. Set the regulator flow dial on the cylinder to Off. Refer to the cylinder user manual.
4. Remove the cylinder and connector fillport covers (if present).
5. To reset the connector, momentarily push DOWN on the outer ring (sleeve) of the connector fillport until GREEN dots are visible.  
If the outer ring (sleeve) is in the UP position (GREEN dots are not visible), the connector fillport will not be able to accept the cylinder fillport. Push DOWN momentarily to reset the connector fillport (GREEN dots visible) to accept the cylinder fillport.
6. Grasp the cylinder in the area behind the cylinder fillport.
7. Position the cylinder in the compressor cradle.
8. Align the cylinder fillport with the connector fillport.
9. To couple the cylinder fillport into the connector fillport, pull UP on the outer ring (sleeve) of the connector fillport while pushing DOWN on the cylinder.  
The cylinder is properly connected when an audible “click” is heard.

## 6.4 Disconnecting the Cylinder from the Compressor

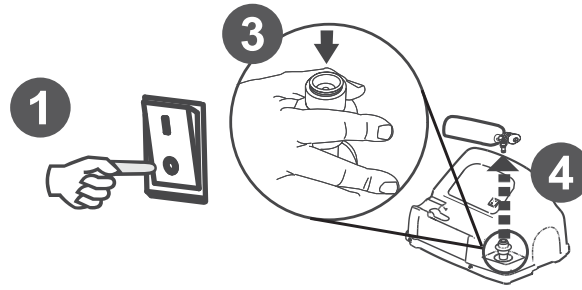

### WARNING!

NEVER use tools of any kind to connect/disconnect the cylinder and the compressor; otherwise, severe injury and/or damage may occur.

1. Press the compressor power switch to the Off (O) position.
2. Grasp the cylinder in the area behind the cylinder fillport.
3. With the other hand, grasp the outer ring (sleeve) of the connector fillport, and push DOWN.
4. Lift up on the cylinder to remove it from the connector fillport.
5. When the cylinder fillport is disconnected from the connector fillport, release the outer ring (sleeve) of the connector fillport, and use two hands to remove the cylinder from the compressor cradle.

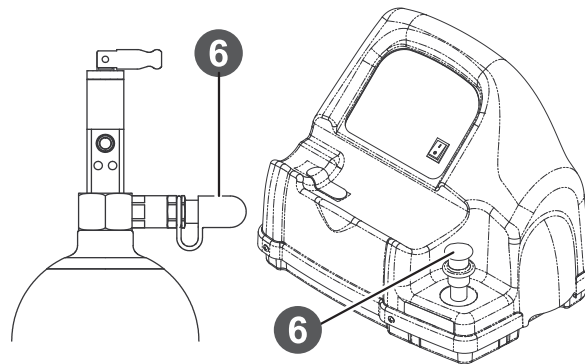

### WARNING!

The fillport cover on the connector fillport and the cylinder fillport MUST be replaced after filling and whenever it is not in use. If either of the fillport covers are missing, contact your healthcare provider before using.

6. Place the fillport covers onto the connector and cylinder fillports.

When using the post valve-type cylinder, attach an oxygen regulator per the manufacturer instructions.

7. Examine the cylinder gauge to ensure the cylinder is full (the needle points into the GREEN area). If the cylinder is not full, perform the following:
  - A. Repeat 6.3 Connecting the Cylinder to the Compressor, page 25.
  - B. If the cylinder is not full after the second attempt to fill, contact the provider.

## 6.5 Turning the Compressor On and Off

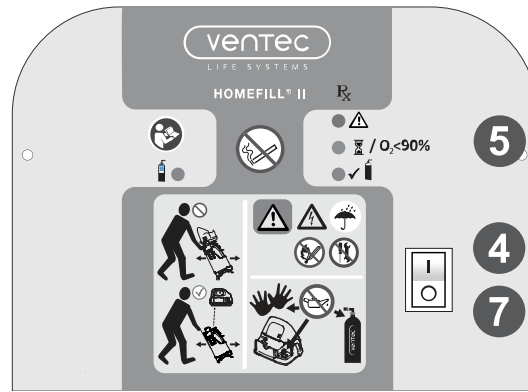

1. Make sure the concentrator is On. Refer to the concentrator user manual.

 The maximum oxygen concentrator flow rate for patient use is listed in the following table. Otherwise, the oxygen level to the compressor will be <90% and the compressor will not fill the cylinder.

Oxygen Concentrator	Maximum Output Flow for Patient Use
Perfecto2™ 5L models	3 L/min
Platinum® 5L models	3 L/min
Platinum® 10L models	5 L/min



 Patients with a higher prescribed flow should not refill a cylinder while receiving supplemental oxygen treatment from the oxygen concentrator.

If your concentrator is not in the ranges listed in the table, refer to your user manual or contact your provider.

2. Set the concentrator flow rate to the patient to one of the following settings. Refer to the concentrator user manual.

- 3 L/min or less for 5L models
- 5 L/min or less for 10L models

 Non-Ventec concentrators may require lower output flow rates to the patient in order to provide  $\geq 90\%$  oxygen levels to the HomeFill compressor.

3. Make sure the cylinder is connected to the compressor. Refer to *6.3 Connecting the Cylinder to the Compressor, page 25*.
4. Push the power switch on the control panel to the On ( I ) position.
5. Examine the control panel, and observe the following sequence of events:
  - 0-3 minutes—The O<sub>2</sub> Below Normal (YELLOW) light will be lit while the compressor warms up.
  - After three minutes—The FILLING (GREEN) light will be on while the cylinder is filling.
  - When the cylinder is finished filling—The FULL (GREEN) light will be on.
    -  The O<sub>2</sub> BELOW NORMAL (YELLOW) light may come on if the oxygen level from the concentrator has not yet reached or drops below 90%. The compressor will begin or resume filling when the oxygen level reaches 90%. If light does not go Off within 10 minutes, refer to *9.1 Troubleshooting Label, page 32*.
    -  If the ATTENTION (RED) light and audible alarm are on, see *9.2 Troubleshooting, page 32*.
6. Remove the full cylinder. See *6.4 Disconnecting the Cylinder from the Compressor, page 26*.
7. Push the power switch to the Off (O) position.
  -  For cylinder operation and use, refer to the cylinder/regulator assembly user manual.

## 7 Maintenance

---

### 7.1 Maintenance Information



#### **WARNING!**

#### **Risk of Injury or Damage**

Lack of product maintenance can lead to injury and loss of product function or damage.

- Maintenance **MUST** be performed **ONLY** by qualified personnel.
- Regular maintenance is necessary to assure proper operation.



#### **WARNING!**

#### **Risk of Injury or Damage**

- The cylinder assembly **MUST** be disconnected from the HomeFill and emptied of gas prior to cleaning or disinfecting. Refer to the cylinder user manual. The fillport cover **MUST** also be installed.
- All cylinders **MUST** be inspected before attempting to fill; otherwise, injury or damage may occur. See *6.2 Cylinder Prefill Inspection, page 23*.



**DANGER!**  
**Risk of Fire**

Dirt or contaminants on the cylinder assembly can cause fire.

- DO NOT use or fill cylinder assembly if the cylinder fillport is dirty or contaminated. Contact your provider for service or repair.
- DO NOT clean with aromatic hydrocarbons, including, but not limited to benzene and toluene.
- DO NOT use cleaning/disinfecting solutions on the fillport fitting.
- DO NOT immerse product in any kind of liquid.
- DO NOT allow any kind of liquid to get inside openings of the cylinder fillport.
- DO NOT spray cleaning/disinfecting solutions on product.
- All repairs MUST be performed by Ventec or in a Ventec-approved repair center.

The cannula does not require maintenance and needs to be replaced at the manufacturer's recommended interval.

The aluminum cylinder must undergo hydrostatic testing every 5 years. See *6.2.1 Hydrostatic Testing Date, page 24*.

## 7.2 Wear and Tear

Ventec reserves the right to ask for any item back that has an alleged defect in workmanship. See the warranty in this manual for specific warranty information.

Refer to the procedures in this manual for proper preventative maintenance schedule and use of the product.

This is a general guideline only and does not include items damaged due to abuse and misuse. Useful life is dependent upon many factors.

Normal wear-and-tear items and components for this product are listed below:

- All types of filters
- All types of tubing

## 7.3 Service Life

The expected service life of this product is five years or 5000 hours of operation when used in accordance with the safety instructions, maintenance intervals and correct use, as stated in this manual. The effective service life can vary according to frequency and intensity of use. Maintenance should be done at least every week.

## 7.4 Cleaning the Compressor Filter



### WARNING!

- Push the power switch to the Off (O) position, and unplug the compressor before cleaning it.
- DO NOT operate the compressor without the filter installed.
- DO NOT unplug the compressor by pulling on the cord. To unplug it, grasp the plug and not the cord. Otherwise, damage may occur.



All compressors have one filter on the back of the cabinet. Perform this procedure at least once each week.

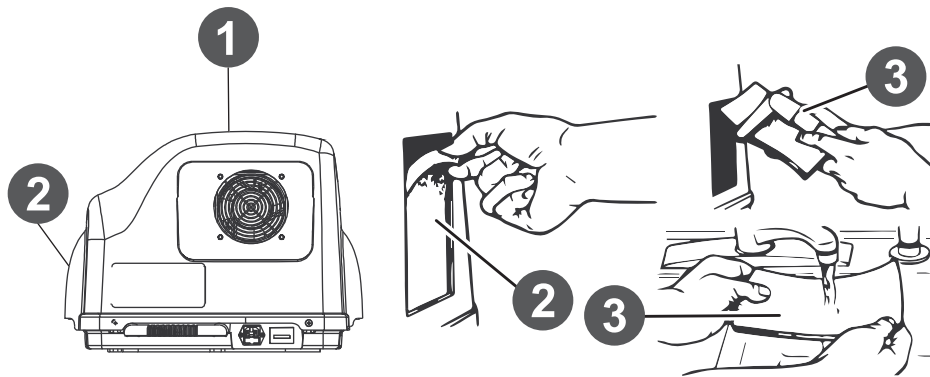

1. Unplug the compressor. Grasp the plug, not the cord.
2. Remove the filter.
3. Clean the filter with a vacuum cleaner, or wash in warm, soapy water and rinse thoroughly.
4. Dry the filter thoroughly before reinstallation.

## 7.5 Cleaning the Cabinet



### DANGER!

#### Risk of Electric Shock

This unit contains moving and high-pressure components. There are no user-serviceable parts inside the cover. To avoid electric shock, injury or death:

- DO NOT remove the cover.
- Refer servicing to qualified personnel.

1. Clean the cabinet with a mild household cleaner and a non-abrasive cloth or sponge.

## 7.6 Replacing the Fuse

 Fuse puller or flathead screwdriver

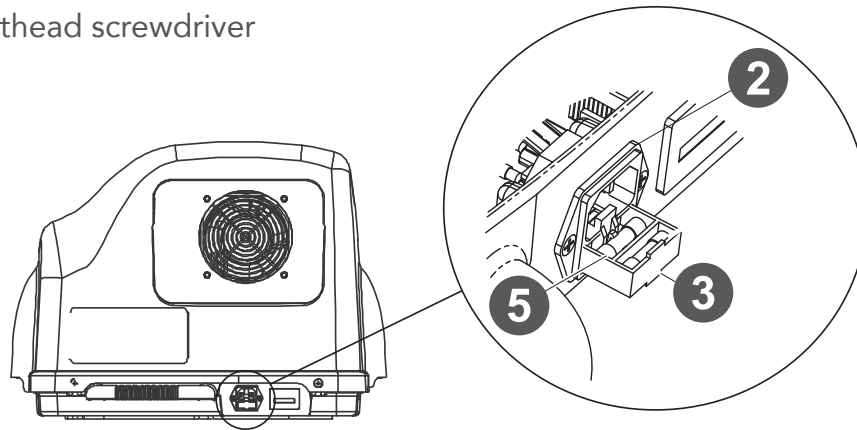

1. Unplug the power cord from the electrical outlet.
2. Remove the power cord from the power inlet on the compressor base.
3. Pull out the fuse drawer at the bottom of the power inlet.
4. Using a fuse puller or a small flathead screwdriver, remove the front fuse inside the fuse drawer and discard it.

 The fuse drawer contains space for two fuses. The front location is for the operational fuse. The unit is supplied with the front fuse only. The rear location is for an optional spare fuse. When replacing the front fuse, ensure there is a spare fuse with the same type and rating in the fuse drawer.

5. Install the replacement fuse in the front fuse slot.

 Use a 5 mm x 20 mm, time lag, low breaking capacity, 250 V, 2 Amp, IEC 60127 style only (Ventec part number 1099820).

6. Push the fuse drawer back into the power inlet.
7. Install the power cord into the power inlet on the compressor base.
8. Plug the power cord into an electrical outlet.
9. Turn the power switch to the On (I) position, and check to see that the unit powers up properly.
10. If the unit does not come on, turn the power switch to the Off position, unplug the power cord and call your dealer, provider or Ventec for service.

## 8 After Use

### 8.1 Disposal

This product may contain substances that could be harmful to the environment if disposed of in places (landfills) that are not appropriate according to legislation.

Follow local governing ordinances and recycling plans regarding disposal of the device or components normally used in operation. The device does not generate waste or residue in operation.

- DO NOT dispose of the device in the normal waste stream.
- Any accessories not part of the device MUST be handled in accordance with the individual product marking for disposal.

## 9 Troubleshooting

### 9.1 Troubleshooting Label

The Troubleshooting label is on the rear of the device and covers the most common issues.

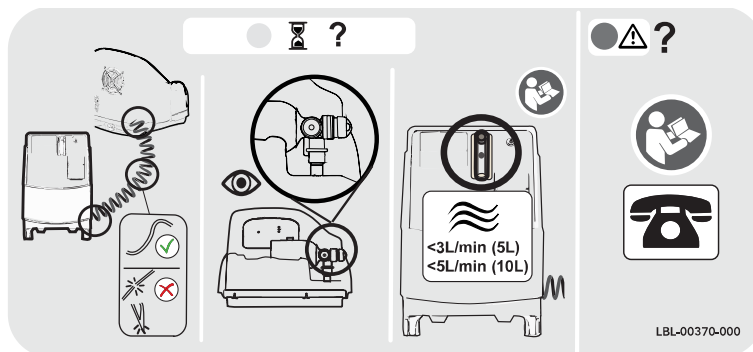

1. If there is a Yellow light:
  - Check the connector tubing for breaks, blockages or damage.
  - Check the cylinder connection.
  - Check the concentrator flow rate. The concentrator flow rate must be less than 3 L/min for 5 L concentrators and 5 L/min for 10 L concentrators.
2. If there is a Red light: The compressor may need service. Refer to *9.2 Troubleshooting, page 32* or *contact your provider*.

### 9.2 Troubleshooting

Problem	Solution
No indicator lights on when the compressor is turned On	<ol style="list-style-type: none"> <li>1. Turn the compressor Off (O).</li> <li>2. Check that the power cord is properly plugged into the compressor and a wall outlet.</li> <li>3. Turn the compressor On (I).</li> <li>4. Clean the air filters. See 7.4 Cleaning the Compressor Filter, page 30.</li> <li>5. If performing steps 1-4 does not cause any indicator lights to come on, contact your home health care provider or Ventec for service.</li> </ol>
RED light is on	<ol style="list-style-type: none"> <li>1. Check the cylinder gauge to see if it is full:                             <ul style="list-style-type: none"> <li>• Cylinder full—Remove the cylinder and turn the unit Off (O). Perform the 6.2 Cylinder Prefill Inspection, page 23 with a cylinder that is not full.</li> <li>• Cylinder not full—Proceed to step 2.</li> </ul> </li> <li>2. Check that the cylinder is properly connected.</li> <li>3. Turn the compressor Off (O).</li> <li>4. Remove the cylinder and reinstall.</li> <li>5. Turn the compressor On (I). If the cylinder is not full and is connected properly, the compressor may have an internal failure. Contact your home health care provider or Ventec for service</li> </ol>



Problem	Solution
Compressor cycles on and off or O <sub>2</sub> Below Normal (yellow) and filling (green) lights are alternating or O <sub>2</sub> below normal (yellow) light	<ol style="list-style-type: none"> <li>1. Check that the concentrator liter flow setting is at or below the flow setting listed in see 6.5 Turning the Compressor On and Off, page 27. If necessary, adjust the liter flow setting (refer to the concentrator user manual). Wait at least 20 minutes for the GREEN light to appear. If it does not appear, proceed to the next step.</li> <li>2. The concentrator may need service. Contact your home health care provider or Ventec.</li> </ol>
O <sub>2</sub> below normal (yellow) light stays on	<ol style="list-style-type: none"> <li>1. Ensure the concentrator has warmed up for at least 20 minutes. If it has not been 20 minutes, turn the compressor Off (O) until the concentrator warms up. If the yellow light remains on, proceed to step 2.</li> <li>2. Inspect the connection between the compressor and the concentrator for damage or pinching. <ul style="list-style-type: none"> <li>• If the connection is damaged, replace it.</li> <li>• If the connection is pinched: <ol style="list-style-type: none"> <li>1. Straighten the tubing.</li> <li>2. Turn the compressor Off (O) for at least 10 seconds.</li> <li>3. Turn the compressor On (I). If the yellow light remains on after 10 minutes, proceed to the next step.</li> <li>4. Contact your home health care provider or Ventec. The concentrator may need service.</li> </ol> </li> </ul> </li> </ol>
Fill times exceed maximum recommended fill times or Green filling light stays on	<ol style="list-style-type: none"> <li>1. Ensure the cylinder regulator flow control valve is set to Off (O).</li> <li>2. Check the recommended fill times in the cylinder manual.</li> <li>3. Check that the cylinder is connected properly. Turn the compressor Off (O). Remove the cylinder and reinstall it. Turn the compressor On (I).</li> <li>4. Check the compressor/concentrator line for proper connection and/or damage, such as leaks or kinks.</li> <li>5. Check that the concentrator liter flow setting is at or below the flow setting listed in 6.5 Turning the Compressor On and Off, page 27. <ul style="list-style-type: none"> <li>• If necessary, adjust the liter flow setting. Refer to the concentrator user manual. If the green filling light does not go off, the compressor and/or concentrator may need service. Contact your home health care provider or Ventec.</li> </ul> </li> </ol>
Excessive noise when compressor is on	Call your home health care provider or Ventec for service.
Hissing sound from regulator when flow selector is off	<ol style="list-style-type: none"> <li>1. Turn the flow selector Off (O).</li> <li>2. If the hissing sounds continue, call your home health care provider or Ventec.</li> </ol>
Regulator is on, but O <sub>2</sub> is not being delivered	<ol style="list-style-type: none"> <li>1. Refill the cylinder.</li> <li>2. Check that the cannula is straight and not pinched. If it is damaged, replace it.</li> <li>3. Call your home health care provider or Ventec for service.</li> </ol>

## 10 Technical Data

### 10.1 Technical Description

The HomeFill Oxygen System (IOH200) is an electromechanical prescription system for use in the home. Its intended function and use is to supply pressurized oxygen to fill Ventec proprietary oxygen cylinders for ambulatory use while the patient receives therapeutic oxygen from an oxygen concentrator. The IOH200 HomeFill compressor is designed for use with oxygen concentrators that meet the input specifications for pressure, flow and oxygen purity.

The HomeFill Oxygen System consists of the IOH200 oxygen compressor, connection tubing and the Ventec-supplied portable oxygen cylinders with interlocking fill fitting.

The IOH200 compressor consists of a multistage compressor, internal reservoir, control electronics with an integral oxygen concentration sensor, interlocking fill fitting, inlet fitting and drive motor. The compressor operation is controlled by the electronics assembly. The motor/compressor is allowed to fill a cylinder only when the oxygen concentration of the inlet gas stream is greater than 90%. The motor/compressor fill operation is completed when the gas in a cylinder reaches the maximum fill pressure of 2000 PSI (13786 kPa).

The IOH200 oxygen compressor can fill cylinders for portable use by ambulatory patients. The Ventec-supplied portable gas cylinders have an interlocking fill fitting that mates only with the Ventec IOH200 compressor assembly.

### 10.2 Specifications

Regulatory Listings	
Regulatory Listings:	Double-Insulated Product
	ETL Certified as Complying with UL60601-1, First Edition
	ETL Certified Complying with CAN/CSA C22.2 No. 601-1 M:90 (Canada)
	EMC IEC 60601-1-2 :2014

Input Specifications	
Input Pressure Required	5-25 psi
Input Flow Required:	2 L/min
Input oxygen Purity Required:	>90% O <sub>2</sub>

General Specifications	
Electrical Requirements:	
Voltage Input:	120 VAC ± 10% (108 VAC/132 VAC), 60 Hz
Rated Current Input:	2.0 AMP
Environmental Conditions:	50°F to 95°F (10°C to 35°C) @ 20 to 60% non-condensing humidity
Recommended Storage and Shipping Environmental Conditions:	-20°F to 150°F (-29°C to 65°C) at 15 to 95% relative humidity

<b>General Specifications</b>	
Width:	20 ¼ inches (51.4 cm)
Height:	15 inches (38.1 cm)
Depth:	16 inches (40.6 cm)
Weight:	33 lb (15.0 kg)
Shipping Weight:	39 lb (17.7 kg)
No AP/APG:	Not suitable for use in the presence of a flammable anesthetic mixture.
Electrical:	No extension cords.
Placement:	No closer than 3 inches (7.5 cm) from any wall, furniture, draperies or furniture to assure sufficient air flow. Avoid deep-pile carpets and heaters, radiators or hot air registers.
Environment:	Smoke and soot free. No confined spaces (Example: No closets).
Altitude:	Up to 6,000 ft (1828 m) above sea level. Atmospheric Pressure Range: 101.3 kPa to 81.2 kPa

### 10.3 Electromagnetic Compliance (EMC)

#### Guidance and manufacturer's declaration—electromagnetic emission

The device is intended for use in the electromagnetic environment specified in the following table. The customer or the user of the device should assure it is used in such an environment.

Emissions Test	Compliance	Electromagnetic Environment Guidance
RF emissions CISPR 11	Group I	The device uses RF energy only for its internal function. Therefore, its RF emissions are very low and are not likely to cause any interference in nearby electronic equipment.
RF emissions CISPR 11	Class B	The device is suitable for use in all establishments including domestic establishments and those directly connected to the public low-voltage power supply network that supplies buildings used for domestic purposes.
Harmonic emissions IEC 61000-3-2	Class A	
Voltage fluctuations/ flicker emissions IEC 61000-3-3	Complies	

#### Guidance and manufacturer's declaration—electromagnetic immunity

The device is intended for use in the electromagnetic environment specified in the following table. The customer or the user of the device should assure it is used in such an environment.

Immunity Test	IEC 60601 Test Level	Compliance Level	Electromagnetic Environment Guidance
Electrostatic Discharge (ESD) IEC 61000-4-2	± 2, 4, 8 kV contact ± 2, 4, 8, 15 kV air	± 2, 4, 8 kV contact ± 2, 4, 8, 15 kV air	Floors should be wood, concrete or ceramic tile. If floors are covered with synthetic material, the relative humidity should be at least 30%.
Electrical fast transient/burst IEC 61000-4-4	± 2 kV mains, 100 kHz	± 2 kV mains, 100 kHz	Mains power quality should be that of a typical commercial or hospital environment.
Surge IEC 61000-4-5	± 1 kV line(s) to line(s) ± 2 kV line(s) to ground	± 1 kV line(s) to line(s) ± 2 kV line(s) to ground	Mains power quality should be that of a typical commercial or hospital environment.
Voltage dips IEC 61000-4-11	0% $U_T$ ; 1/2 cycle @ 0, 45, 90, 135, 180, 225, 270, and 315 and 0% $U_T$ ; 1 cycl and 70% $U_T$ ; 25/30 cycles Single phase: at 0°	0% $U_T$ ; 1/2 cycle @ 0, 45, 90, 135, 180, 225, 270, and 315 and 0% $U_T$ ; 1 cycl and 70% $U_T$ ; 25/30 cycles Single phase: at 0°	Mains power quality should be that of a typical commercial or hospital environment. If the user of the device requires continued operation during power mains interruptions, it is recommended the device be powered from an un-interruptible power supply or a battery. $U_T$ is the a. c. mains voltage prior to application of the test level.

Immunity Test	IEC 60601 Test Level	Compliance Level	Electromagnetic Environment Guidance														
Voltage interruptions IEC 61000-4-11	0% $U_T$ ; 250/300 cycle	0% $U_T$ ; 250/300 cycle	Mains power quality should be that of a typical commercial or hospital environment. If the user of the device requires continued operation during power mains interruptions, it is recommended the device be powered from an un-interruptible power supply or a battery. $U_T$ is the a. c. mains voltage prior to application of the test level.														
Power frequency (50/60 Hz) magnetic field IEC 61000-4-8	30 A/m, 50/60 Hz	30 A/m, 50/60 Hz	Power frequency magnetic fields should be at levels characteristic of a typical location in a typical commercial or hospital environment.														
<table border="0"> <tr> <td>Conducted RF IEC 61000-4-6</td> <td>3 Vrms, 6 Vrms</td> <td>3 Vrms, 6 Vrms</td> <td> <table border="0"> <tr> <td><math>d = 1.2\sqrt{P}</math></td> <td>150 kHz to 80 MHz</td> </tr> <tr> <td><math>d = 0.35\sqrt{P}</math></td> <td>80 MHz to 800 MHz</td> </tr> <tr> <td><math>d = 0.7\sqrt{P}</math></td> <td>800 MHz to 2,5 GHz</td> </tr> </table> </td> </tr> <tr> <td>Radiated RF IEC 61000-4-3</td> <td>10 V/m</td> <td>10 V/m</td> <td></td> </tr> </table>	Conducted RF IEC 61000-4-6	3 Vrms, 6 Vrms	3 Vrms, 6 Vrms	<table border="0"> <tr> <td><math>d = 1.2\sqrt{P}</math></td> <td>150 kHz to 80 MHz</td> </tr> <tr> <td><math>d = 0.35\sqrt{P}</math></td> <td>80 MHz to 800 MHz</td> </tr> <tr> <td><math>d = 0.7\sqrt{P}</math></td> <td>800 MHz to 2,5 GHz</td> </tr> </table>	$d = 1.2\sqrt{P}$	150 kHz to 80 MHz	$d = 0.35\sqrt{P}$	80 MHz to 800 MHz	$d = 0.7\sqrt{P}$	800 MHz to 2,5 GHz	Radiated RF IEC 61000-4-3	10 V/m	10 V/m				<p>Portable and mobile RF communications equipment should be used no closer to any part of the device, including cables, than the recommended separation distance calculated from the equation applicable to the frequency of the transmitter. Recommended separation distance:</p> <p>where P is the maximum output power rating of the transmitter in watts (W) according to the transmitter manufacturer, and d is the recommended separation distance in metres (m). Field strengths from fixed RF transmitters, as determined by an electromagnetic site survey,<sup>a</sup> should be less than the compliance level in each frequency range.<sup>b</sup> Interference may occur in the vicinity of equipment marked with the following symbol:</p> 
Conducted RF IEC 61000-4-6	3 Vrms, 6 Vrms	3 Vrms, 6 Vrms	<table border="0"> <tr> <td><math>d = 1.2\sqrt{P}</math></td> <td>150 kHz to 80 MHz</td> </tr> <tr> <td><math>d = 0.35\sqrt{P}</math></td> <td>80 MHz to 800 MHz</td> </tr> <tr> <td><math>d = 0.7\sqrt{P}</math></td> <td>800 MHz to 2,5 GHz</td> </tr> </table>	$d = 1.2\sqrt{P}$	150 kHz to 80 MHz	$d = 0.35\sqrt{P}$	80 MHz to 800 MHz	$d = 0.7\sqrt{P}$	800 MHz to 2,5 GHz								
$d = 1.2\sqrt{P}$	150 kHz to 80 MHz																
$d = 0.35\sqrt{P}$	80 MHz to 800 MHz																
$d = 0.7\sqrt{P}$	800 MHz to 2,5 GHz																
Radiated RF IEC 61000-4-3	10 V/m	10 V/m															

<sup>a</sup> Field strengths from fixed transmitters, such as base stations for radio (cellular/cordless) telephones and mobile radios, amateur radio, AM and FM radio broadcast and TV broadcast cannot be predicted theoretically with accuracy. To assess the electromagnetic environment due to fixed RF transmitters, an electromagnetic site survey should be considered. If the measured field strength in the location in which the device is used exceeds the applicable RF compliance level listed above, the device should be observed to verify normal operation. If abnormal performance is observed, additional measures, such as reorienting or relocating the device, may be necessary.

<sup>b</sup> Over the frequency range 150 kHz to 80 MHz, field strengths should be less than [V1] V/m. At 80 MHz and 800 MHz, the higher frequency range applies.

## Recommended separation distances between portable and mobile RF communications equipment and the device

The device is intended for use in an electromagnetic environment in which radiated RF disturbances are controlled. The customer or the user of the device can help prevent electromagnetic interference by maintaining a minimum distance between portable and mobile RF communications equipment (transmitters) and the device as recommended in the following table, according to the maximum output power of the communications equipment.

Rated maximum output of transmitter [W]	Separation distance according to frequency of transmitter [m]		
	150 kHz to 80 MHz $d = 1.2\sqrt{P}$	80 MHz to 800 MHz $d = 0.35\sqrt{P}$	800 MHz to 2,5 GHz $d = 0.7\sqrt{P}$
0.01	0.12	0.04	0.07
0.1	0.37	0.11	0.22
1	1.17	0.35	0.70
10	3.69	1.11	2.21
100	11.67	3.50	7.00

For transmitters rated at a maximum output power not listed above the recommended separation, distance in meters (m) can be estimated using the equation applicable to the frequency of the transmitter, where P is the maximum output power rating of the transmitter in watts (W), according to the transmitter manufacturer.

At 80 MHz and 800 MHz, the separation distance for the higher frequency range applies.

These guidelines may not apply in all situations. Electromagnetic propagation is affected by absorption and reflection from structures, objects and people.

# 11 Warranty

---

## 11.1 Limited Warranty

 THE WARRANTY BELOW HAS BEEN DRAFTED TO COMPLY WITH FEDERAL LAW APPLICABLE TO PRODUCTS MANUFACTURED AFTER JULY 4, 1975.

This warranty is extended only to original purchaser who purchases this product when new and unused from Ventec or a provider. This warranty is not extended to any other person or entity and is not transferable or assignable to any subsequent purchaser or User Coverage under this warranty will end upon any such subsequent sale or other transfer of title to any other person. This warranty gives you specific legal rights and you may also have other legal rights which may vary from state to state.

Ventec warrants the HomeFill Compressor to be free from defects in materials and workmanship for a period of one year from date of purchase from Ventec or a dealer, with a copy of the seller's invoice required for coverage under this warranty.

Ventec warrants the HomeFill internal wear components {piston seals and rings, bearings, drive belts, check valves, pressure relief components and electric motor) for a period of three years from the date of purchase from Ventec or a dealer, with a copy of the seller's invoice required for coverage under this warranty, or 5,000 hours, whichever comes first. Ventec warrants the HomeFill control panel components {electrical switches, reset switch and indicator lights) for a period of three years from the date of purchase from Ventec or a dealer, with a copy of the seller's invoice required for coverage under this warranty, or 5,000 hours, whichever comes first.

DO NOT OPEN OR ATTEMPT TO SERVICE UNLESS SERVICE IS PROVIDED BY A VENTEC-CERTIFIED TECHNICIAN; otherwise, this will void any and all warranties. If within such warranty periods any such product shall be proven to Ventec's satisfaction to be defective, such product shall be repaired or replaced, at Ventec's option. This warranty only applies to the labor for repairs performed by the Ventec Service Department or Ventec dealers. It does not apply to the labor performed by the purchaser or user. This warranty does not include normal wear and tear, failure to adhere to the product instructions, or shipping charges incurred in replacement part installation or repair of any such product. Ventec's sole obligation and your exclusive remedy under this warranty shall be limited to such repair or replacement. Routine maintenance items, such as filters, are excluded from this warranty.

Terms and conditions of the warranty are part of the general terms and conditions particular to the individual countries in which this product is sold.

Contact information for your local Ventec office is located on or inside the back cover of this manual.



**Ventec Life Systems, Inc.**

22002 26th Ave SE Bothell, WA 98021 United States

844-698-6276

[www.reacthealth.com](http://www.reacthealth.com)



Manufacturer

**Ventec Life Systems , Inc.**

22002 26th Ave SE Bothell, WA 98021 USA